

# 外形尺寸

SQP31 (法兰安装型)

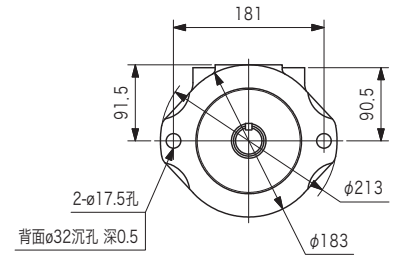

SQPS31 (法兰安装型)

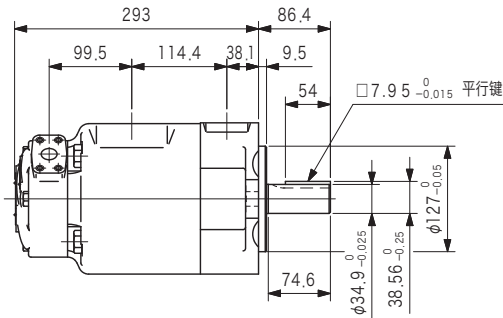
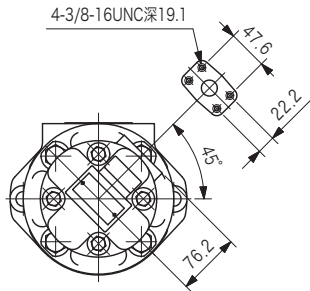
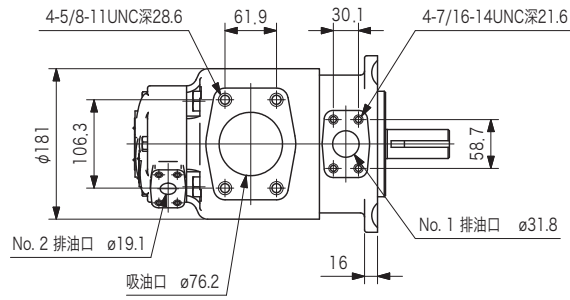
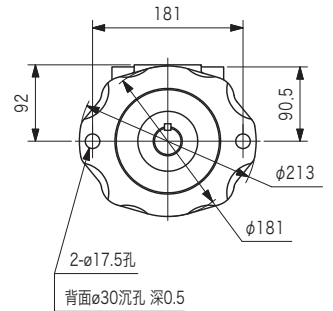
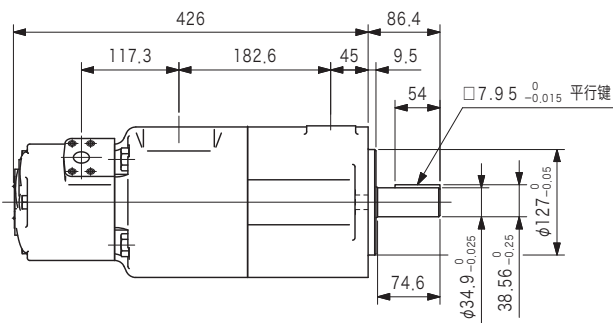
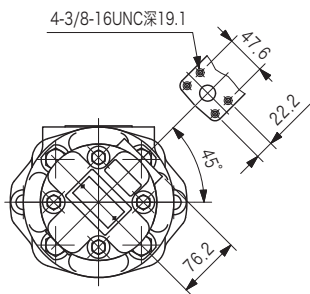
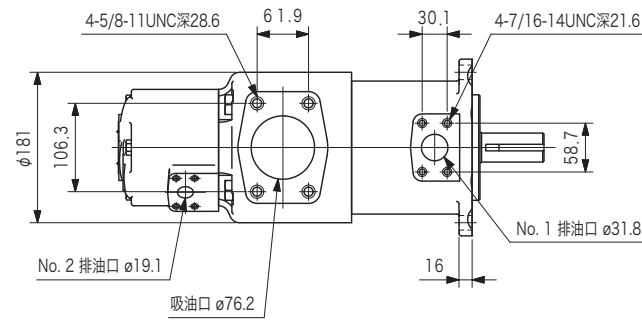

脚架安装型

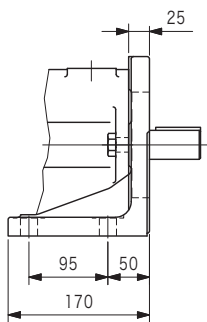

SQPS31

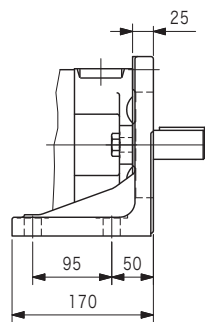

SQP31

